

First Alert®

2190DF / 2575DF / 2700DF / 2702DF

First Alert®

MANUAL # M08-0284-004

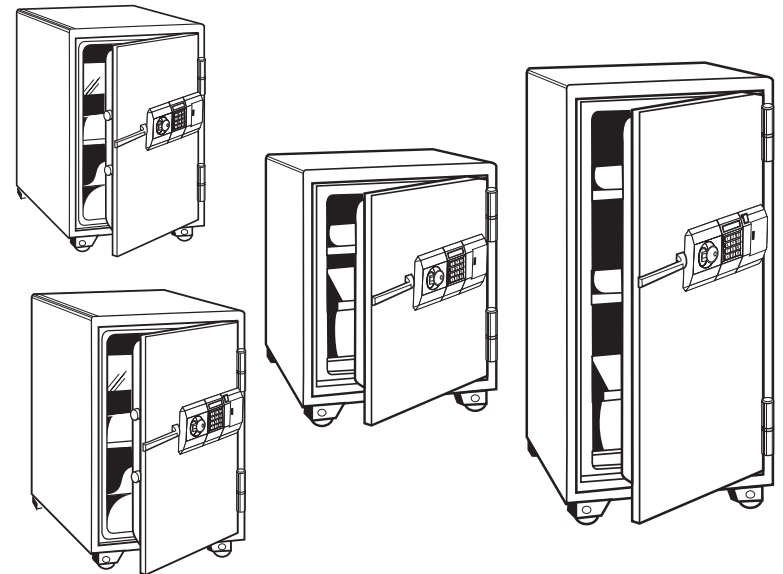

www.FirstAlert.com

**FIRE THEFT SAFE
WITH DIGITAL LOCK**



INDEX

Overview of Your Safe	1
Programming Preparation	3
Programming a Passcode	4
Opening & Closing Digital Safe	5
Additional Features: Removable Shelves	6
Consumer Affairs	7
Use, Care & Maintenance	8
Limited Warranty	9-10

FOR YOUR PROTECTION

- ✓ Do not remove the serial number tag from the safe.
- ✓ Record all safe identification numbers on Safe Identification Record on page 7.
- ✓ Save this manual and NEVER keep it inside the safe.

OVERVIEW OF YOUR SAFE

Welcome!

Your new First Alert® Fire Theft Safe™ will provide years of safe and secure protection for your valuables, important documents and other personal items. All First Alert® Safes are designed and built using the highest manufacturing standards to ensure maximum user satisfaction under a variety of conditions. With proper care, your First Alert® Safe will provide peace of mind for many years to come.

The next page outlines the items and quantities of each included with your new safe. Please carefully check the list to confirm all items have been received. If any item is missing, please contact Consumer Affairs: 1-800-323-9005.

PACKAGE CONTENTS

Models 2190DF, 2575DF, 2700DF, 2702DF

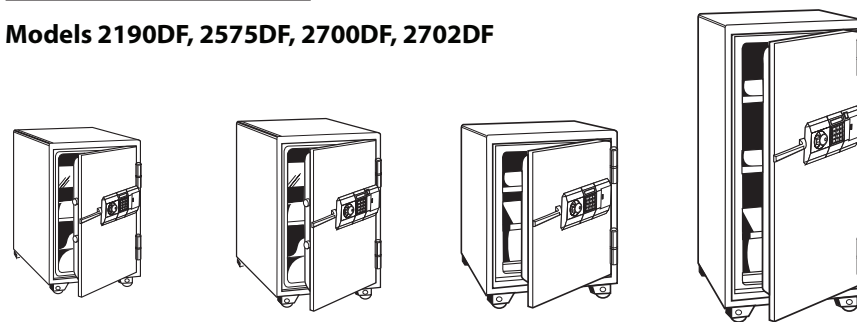

- | | |
|--|------|
| A. Operation & Installation Guide | 1 ea |
| B. Companion Keys | 2 ea |
| C. Storage Drawer Keys (2700 / 2702) | 2 ea |
| D. Removable Shelves (Only 1 for 2190) | 2 ea |
| E. Shelf Support Clips (Only 4 for 2190) | 8 ea |
| F. AA Batteries | 4 ea |

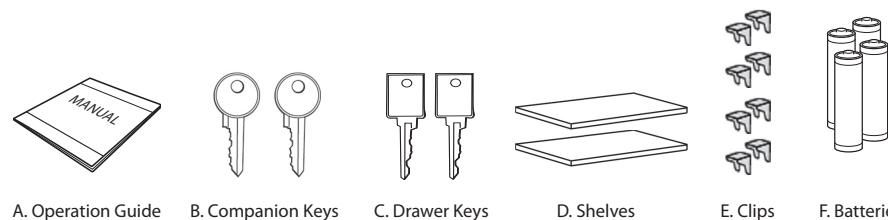

A. Operation Guide B. Companion Keys C. Drawer Keys D. Shelves E. Clips F. Batteries

⚠ IMPORTANT: DO NOT RETURN SAFE TO STORE

If you are missing parts, have difficulty programming your safe or have any other questions pertaining to its proper use and care, DO NOT RETURN your safe to the store. Please contact Consumer Affairs at 1-800-323-9005, 7:30 am – 5:00 pm Central Standard Time, Monday through Friday. To assist us in serving you, please have the model number and date of purchase available when calling.

PROGRAMMING PREPARATION

INSTALLING BATTERIES

The digital keypad is powered by 4 AA batteries which must be installed before you can begin programming your personal code. For your convenience, we have provided you with 4 AA batteries. For best results and depending on use, we recommend replacing the batteries at least once a year.

- 1 Locate battery compartment to the right of the digital keypad.
- 2 To open the compartment, press firmly on the battery cover and slide it to the right for removal.
- 3 Install 4 new AA batteries in the battery compartment. Make sure they are installed in the correct direction as marked on the inside of the battery compartment.
- 4 Once the batteries are installed properly, replace the cover by sliding it back on from the left.

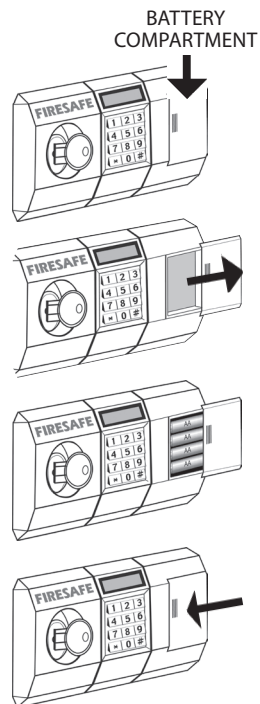

⚠ IMPORTANT: BATTERY REMOVAL

If the batteries are removed or fail, the keypad memory will NOT be erased.

⚠ IMPORTANT: OVERRIDE ENTRY TO SAFE

In the event that you forget your passcode, you can obtain a Master Override Code to gain entry into your safe. Contact our Customer Affairs Department at 1-800-323-9005 to get instructions on how to obtain this code. It takes some time to complete your request, therefore it is recommended that this be done immediately so in the event that you forget your passcode, you will be prepared to immediately gain access to your safe using your Master Override Code. (See page 5 for instructions on how to open your safe using the Master Override Code).

PROGRAMMING A PASSCODE

LCD DISPLAY MENU

Your new Digital Firesafe features an LCD display to assist in programming and operating your safe. A menu of the codes is as follows:

<i>OPEn</i>	Ready to enter your passcode
<i>CodE</i>	Ready to program passcode
<i>Good</i>	Correct passcode entered
<i>Error</i>	Incorrect passcode entered
<i>Lo-bA</i>	Batteries (AA) must be replaced

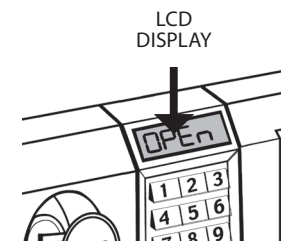

PROGRAMMING A PASSCODE

Use the digital keypad to program your own 3 to 8 digit passcode. You may choose or change your personal passcode at any time by following these steps:

- 1 Open the safe as described in "Open Safe with Passcode & Key" section on the following page. Press * and enter the factory pre-set Passcode: **1 - 2 - 3 - 4 - #** to open the safe for the first time or your user programmed Passcode if the pre-set Passcode has already been changed.
- 1 Locate the memory button marked on the inside of the door.
- 2 Using a pen or other blunt tip, quickly push and release the memory button.
- 3 After you hear a "beep", the LCD display will read "Code" and you may begin entering your personal code (from 3 - 8 digits) followed by the # button.
- 4 Next you will hear a longer "beep" and the LCD display will flash the code you entered and disappear, indicating that your personal code has been successfully programmed and can now be used to open your safe.

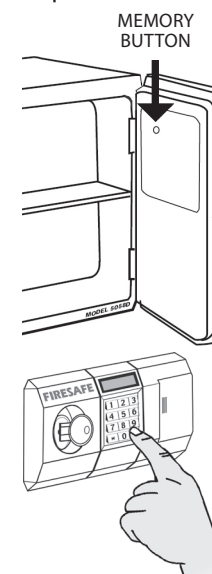

⚠ IMPORTANT: SECURITY LOCKOUT PERIODS

For added security, the safe will automatically "Lockout" entry for 5 minutes after three attempts to open with an invalid passcode. After three more invalid attempts within this time period, a one-hour "Lockout" period will begin. During these "Lockout" periods, entry **MUST BE MADE** using the emergency override key.

OPENING SAFE WITH PASSCODE & KEY

OPENING THE SAFE

Once your passcode has been entered into the memory, the safe can be opened by following these simple steps:

- 1 Insert one of the Companion Entry Keys (round top) into the lock cylinder but **DO NOT TURN KEY**.
- 2 Press the * button on the keypad, followed by the programmed code (use **1 – 2 – 3 – 4** when opening the safe for the first time) and the # button.
- 3 The LCD display will read "Good" and you will hear a tone indicating that the safe door is unlocked.
- 4 To open, turn the Companion Entry Key (round top) to the **RIGHT** and turn the handle.

NOTE: You must open the safe door within 3 seconds or the electronic lock automatically engages.

To program personal passcode, follow steps 1-4 on page 3.

⚠ IMPORTANT: TURN ENTRY KEY TO RIGHT ONLY

Turning it to the left may cause key to become stuck in the cylinder and may cause damage to the lock.

CLOSING THE SAFE

- 1 Make sure the key is in the open position.
- 2 Close the door.
- 3 The handle will automatically return to the closed position.
- 4 Turn the key all the way to the left.
- 5 Remove the key from the lock.

MASTER OVERRIDE CODE USE

The Master Override Code can be obtained from our Consumer Affairs Department. It can be used to gain entry to your safe in the event that you forget your Passcode.

- 1 Press the * button on the keypad and the LCD displays "Open".
- 2 Within 10 seconds, enter the 8-digit Master Override Code followed by #.
- 3 After one minute time delay, LCD displays "Good" along with a melody.
- 4 Within 4 seconds, turn the key to the right to open the safe.

NOTE: You must open the safe door within 3 seconds or the electronic lock automatically engages.

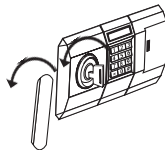

REMOVABLE SHELVES

ADJUSTABLE & REMOVABLE SHELVES

These models are designed with 5 position adjustable shelves to allow greater flexibility and further accommodate your particular security storage needs.

TO INSTALL:

Your shelf and shelf support clips have been shipped inside your safe and wrapped for protection from damage during shipping.

- 1 Remove shelf and (4) shelf support clips from protective wrapping.
- 2 Determine the desired position of your shelf and note the corresponding support guide slots (2 on each side of interior walls) that are best suited to support the shelf in that position.
- 3 Install the (4) shelf support clips in the same position on all four support guides.
- 4 Install shelf into position by placing it inside the safe (tilting if necessary) at a point above the desired position.
- 5 Once inside, lower it into position until resting on shelf support clips.

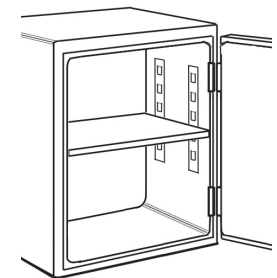
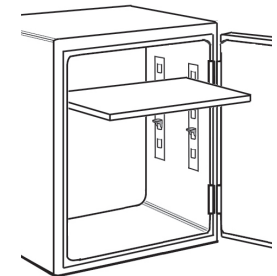
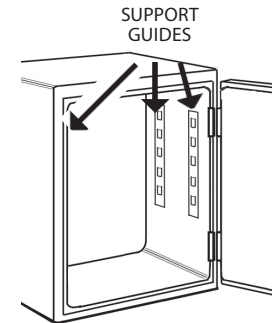

ADJUSTABLE & REMOVABLE SHELVES

Simply remove the shelf and reposition the (4) shelf support clips by sliding them up and out of the support slots and reinstalling them into the new positions. Then reinstall shelf as described above.

⚠ IMPORTANT: REMOVING SHELF

If you remove the shelf, it is strongly recommended that you **DO NOT DISCARD** it. You may lay the shelf flat in the bottom of the safe to assure full flexibility in the future.

CONSUMER AFFAIRS

YOUR SAFE'S UNIQUE IDENTIFICATION NUMBERS

When contacting Consumer Affairs, you should be prepared to supply some important information that specifically identifies your safe. This information is extremely important to assuring prompt and accurate customer assistance. It is strongly recommended that you identify and record the following information in the "Safe Identification Record" form located on the inside back cover of this manual.

MODEL NUMBER

SERIAL NUMBER

KEY NUMBER

LOCATING MODEL & SERIAL NUMBERS

Most First Alert® safes include a small metallic silver or gray tag affixed to one of the surfaces. This tag is usually located on the front or right side of the safe. This tag contains the Serial Number, and on selected models a similar tag is attached containing the Model Number. If a Model Number tag is not attached to the safe, then it can be located on the front or side panel of the box that the safe was packaged in. Write this number down for future reference.

LOCATING KEY NUMBER

The Key Number is located on the key. If you do not have the key, the number is also imprinted on the Key lock.

IMPORTANT: DO NOT REMOVE TAGS

In case your safe becomes inoperable or you lose your keys, these identification numbers will be needed to correct the problem. It is recommended that the number tags remain in place on the safe. If removal is necessary, then they should be attached to the inside back cover of the Operation and Installation Guide. Do not put manual or tags inside the safe. Store in a safe and secure place for future reference.

SAFE IDENTIFICATION RECORD



Model Number _____

Serial Number _____

Key Number _____

Digital Passcode Record #

Your passcode must be at least 3 digits and no more than 8 digits followed by the # sign.

APPROPRIATE USE OF YOUR SAFE

First Alert® fire safes protect paper records and many other valuables. Verified fire protection for: Memory sticks, CD's & DVD's, USB Drives. This product is **NOT INTENDED** to protect audio or video cassettes, floppy discs, data cartridges, film and photos or photo negatives. Your safe must be closed and latched in order to properly protect the contents from fire.

MOISTURE WARNING

We recommend that you place delicate items such as pictures or intricate jewelry into an air-tight container before storing them in your safe. Avoid placing your safe in areas of high humidity. For optimum performance, the safe should be opened and aired out for at least 20 minutes every two weeks.

FIREARMS WARNING

This safe is **not** designed to store medication, items with combustible content, guns or other weapons. Please contact BRK at 800-323-9005 or shop www.FirstAlert.com for information about safes that can securely store your firearms or medication.

PEARLS

Because pearls sustain heat damage at temperatures below 350° F, we advise that you **DO NOT** store pearls in this fire safe.

SAFE CARE & MAINTENANCE

When properly maintained, your safe will continue to operate and accurately read the authorized Passcode for many years. In order to ensure optimum performance of your safe, please follow these simple precautions:

BATTERY MAINTENANCE

We recommend that you place delicate items such as pictures or intricate jewelry into an air-tight container before storing them in your safe. Avoid placing your safe in areas of high humidity. For optimum performance, the safe should be opened and aired out for at least 20 minutes every two weeks.

- 1 Always purchase and use batteries as specified by this User's manual.
- 2 Always replace all batteries at the same time. It is recommended to replace all batteries at least once a year or sooner depending on amount of use.
- 3 Always clean the battery contacts in the battery compartment and on the batteries before installing new batteries.
- 4 Always make sure batteries match polarity (+ / -) signs in the battery compartment.
- 5 If safe will not be used for an exhausted period of time, removing batteries is recommended.
- 6 Always promptly remove and properly discard all used batteries.

CLEAN HANDS

Never attempt to operate the digital keypad if your hands have excessive dirt, debris or liquids on them.

CLEAN SAFE

To clean the surface of your safe, it is recommended that you use a mild cleaner (e.g. window cleaner) to avoid scratching or discoloring the surface. Always wipe dry and **NEVER** use abrasive cleansers on the safe or digital keypad.

For future reference, store this Operation and Installation Guide in a secure area away from the safe.

DO NOT DISCARD!

HOW TO OBTAIN WARRANTY SERVICE

If service is required, do not return the product to your retailer. In order to obtain warranty service, contact the Consumer Affairs Division at 1-800-323-9005, 7:30 am to 5:00 pm Central Standard Time, Monday through Friday. To assist us in serving you, please have the model number and date of purchase available when calling.



PLEASE CALL US AT 1-800-323-9005 TO ESTABLISH A WARRANTY RETURN SET-UP

First Alert, Inc.
Attn: Warranty Safe Returns
1301 Joe Battle
El Paso, TX 79936

RECOVERING LOST COMBINATION & ORDERING REPLACEMENT KEYS

If you forget your combination, you can obtain a Master Override Code from First Alert, Inc. If you lose the Companion Keys or would like additional keys, you can purchase them from First Alert, Inc. You must supply the following information to assure accurate processing:

- ✓ Name / Address / Telephone Number
- ✓ Safe Model Number / Serial Number
- ✓ Key Number (located on the key and on the Companion Key Lock) – Ignore if requesting Master Override Code
- ✓ Notarized statement of ownership
- ✓ Indicate number of keys requested – Ignore if requesting Master Override Code
- ✓ Method for how you would like to receive keys – Ignore if requesting Master Override Code

Checks or Money Orders are required for orders received by mail and should be made payable to First Alert. Contact our Consumer Affairs Department for costing information prior to ordering. Mail to:

First Alert, Inc.
Attn: Consumer Affairs
3901 Liberty Street Road
Aurora, IL 60504-8122

LIFETIME AFTER FIRE REPLACEMENT GUARANTEE

If your First Alert® Firesafe is ever damaged by a fire, BRK will replace it with a comparable model at no charge to the consumer. Freight on the replacement unit is not included in the guarantee and must be paid by the consumer.

For claims, submit your name and address, a photo of the damaged safe along with its Model Number and a copy of the Fire Department report to BRK Consumer Affairs as proof of loss. Once the information is received, Consumer Affairs will contact you with further instructions.

LIMITED WARRANTY

BRK Brands, Inc., (“BRK”) warrants that for a period of five (5) years from the date of purchase, this product will be free from defects in material and workmanship. BRK, at its sole option, will repair or replace this product or any component of the product found to be defective during the warranty period. Replacement or repair will be made with a new or remanufactured product or component. If the product is no longer available, replacement may be made with a similar product of equal or greater value. This is your exclusive warranty. This warranty is only valid for the original retail purchaser from the date of initial retail purchase and is not transferable. You must keep the original sales receipt. Proof of purchase is required to obtain warranty performance. BRK dealers, service centers, or retail stores selling this product do not have the right to alter, modify or in any way change the terms and conditions of this warranty.

This warranty does not apply to the finish on the product. This warranty does not cover normal wear and tear of parts or damage resulting from any of the following: negligent use or misuse of the product, use contrary to the operating instructions, disassembly, repair or alteration by anyone other than BRK or an authorized service center, improper installation, or exposure to extremes of heat or humidity. Further, the warranty does not cover Acts of God, including natural disasters.

BRK shall not be liable for any incidental or consequential damages caused by the breach of any express or implied warranty. BRK is also not responsible for: costs associated with removing or installing the product; damage or loss of the contents of the product; nor for the unauthorized removal of the contents; or damages incurred during shipment. Except to the extent prohibited by applicable law, any implied warranty of merchantability or fitness for a particular purpose is limited in duration to the duration of the above Warranty Period. Some states, provinces or jurisdictions do not allow the exclusion or limitation of incidental or consequential damages or limitations on how long an implied warranty lasts, so the above limitations or exclusion may not apply to you. This warranty gives you specific legal rights, and you may also have other rights that vary from state to state, or province to province, or jurisdiction to jurisdiction.

If you have any questions that cannot be answered by reading this manual, please call Consumer Affairs at 1-800-323-9005.

© 2015 BRK Brands, Inc., a Jarden Corporation company (NYSE: JAH)
3901 Liberty Street Road, Aurora, IL 60504-8122

All rights reserved. www.FirstAlert.com