

FIRST ALERT

Installed On \_\_\_\_\_

Replace by \_\_\_\_\_



Battery



Wired

# Onelink<sup>®</sup>

## Smart Smoke & Carbon Monoxide Alarm

User's Manual Model: 1042135



**Important! Please read carefully and save this document.**

This user's manual contains important information about your combination Smoke and CO Alarm's operation. If you are installing this alarm for use by others, you must leave this manual (or a copy of it) with the end user.

# Table of Contents

Welcome	3
Parts of this Alarm	4
Understanding Your Alarm	5
Where to Install	6 - 7
Where Not to Install	8
Set-Up and Installation	9 - 12
Installation of Adapter Plug	12 - 16
Wireless Interconnect	16 - 17
When the Alarm Sounds	17 - 18
Using the Silence Feature	18
Weekly Testing	19
Regular Maintenance	20
Alarm End of Life	20
Ionization and Photoelectric Technology	21
Fire Safety Tips	21 - 22
What You Need to Know About CO	23
Potential Sources of CO in the Home	24 - 25
Regulatory Information	26 - 28
Special Compliance	29 - 31
General Limitations	31 - 32
Troubleshooting Guide	33
Limited Warranty	34
Copyright and Technical Specifications	35

# Welcome

Thank you for choosing Onelink by First Alert for your safety needs. In addition to the alarm sounds, you can receive notifications in case of an emergency to help provide a warning of a fire or carbon monoxide leak while you are home or away. Please take time to read this manual and make this alarm an integral part of your family's safety plan. Visit [www.onelink.firstalert.com](http://www.onelink.firstalert.com) for additional information.

---

## Contents



**Smoke and  
CO Alarm**



**Mounting  
Bracket**

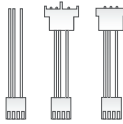

**Power Connector  
/ Adapter Plugs**



**Junction  
Box Screws**



**User's  
Manual**

## System Requirements



**Wireless Network**

Required to use a 2.4 GHz wireless connection and a compatible 802.11 b/g/n/ac router.



**Android or iOS Device**

HomeKit™ requires an iPhone®, iPad®, or iPod touch® with iOS 10 or later, or Android® 5 or later.



**Onelink App**

Search and download the Onelink Home app from the App Store or Google Play.

# Parts of this Alarm

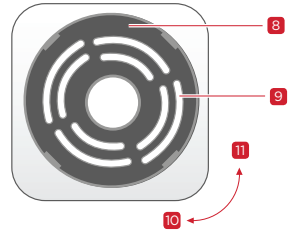
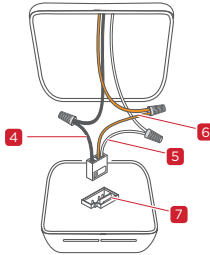
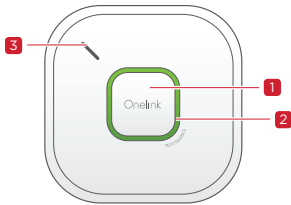

**1. Test/Silence Button**

**2. Color Indicator Ring**

**3. Speaker**

**4. Hot (black) AC Wire**

**5. Neutral (white) AC Wire**

**6. Interconnect  
(orange) AC Wire**

**7. Quick Connect  
Power Connector**





**8. Mounting Bracket**

**9. Mounting Slots**

**10. Turn Alarm Clockwise  
to Attach**

**11. Turn Alarm  
Counterclockwise  
to Remove**

# Understanding Your Alarm

LED Color Patterns	Smoke / CO Events	Voice Guide
 Green	Power Up and Welcome	<p>Power Up</p> <p>"First Alert welcomes you to your Onelink Smoke and Carbon Monoxide Alarm. The Onelink App will guide you through the simple setup process."</p>
	Programming, Silencing & Pairing	"[Location, example: "Hallway"] Location Programmed."
	Testing	"The testing is complete. The test is done and you are protected."
	Emergency	[voice complete]
 Blue	Pairing	Alarm will flash blue during pairing.
 Red	Testing	"Testing Smoke" [beep beep beep!]
		"Testing Carbon Monoxide" [beep beep beep beep!]
		"Evacuate, Evacuate, there's Fire in the [Location]!"
		"Testing Alarms... The alarm will sound and for your protection is very loud. This may take a few seconds."
		"Highest carbon monoxide level was 0 PPM."
	Emergency	<p>"Evacuate! Evacuate! There is Smoke [or Carbon Monoxide] in the [Location]!"</p> <p>"Highest carbon monoxide level was [Number] PPM."</p>
 Yellow	Malfunction	<p>"Detector error."</p> <p>"Alarm has reached its End of Life. Replace Alarm in [Location]."</p>
	Low Battery	Information available via mobile app.
	 White	Power Indicator and Night Light

# Where to Install

Minimum coverage for Smoke Alarms, as recommended by the National Fire Protection Association (NFPA), is one Smoke Alarm on every floor, in every sleeping area, and in every bedroom (See "Regulatory Information For Smoke Alarms" for details on the NFPA recommendations). For CO Alarms, the National Fire Protection Association (NFPA) recommends that a CO Alarm should be centrally located outside of each separate sleeping area in the immediate vicinity of the bedrooms. For added protection, install additional CO Alarms in each separate bedroom, and on every level of your home.

**NOTE:** For added protection, install an additional Smoke/CO Alarm at least 15 feet (4.6 meters) away from the furnace or fuel burning heat source where possible. In smaller homes or in manufactured homes where this distance cannot be maintained, install the Alarm as far away as possible from the furnace or other fuel burning source. Installing the Alarm closer than 15 feet (4.6 meters) will not harm the Alarm, but may increase the frequency of unwanted alarms.

## In general, install combination Smoke and Carbon Monoxide Alarms:

- On every level of your home, including finished attics and basements.
- Inside every bedroom, especially if people sleep with the door partly or completely closed.
- In the hall near every sleeping area. If your home has multiple sleeping areas, install a unit in each. If a hall is more than 40 feet (12 meters) long, install a unit at each end.
- At the top of first-to-second floor stairs.
- At the bottom of the basement stairs.
- For additional coverage, install Alarms in all rooms, halls, and storage areas, where temperatures normally remain between 40° F and 100° F (4.4° C and 37.8° C).

## Recommended Placement

- When installing on the wall, the top edge of Smoke Alarms should be placed between 4 inches (102 mm) and 6 inches (153 mm) from the wall/ceiling line.
- When installing on the ceiling, place the alarm as close to the center as possible.
- In either case, install at least 4 inches (102 mm) from where the wall and ceiling meet.
- See Avoiding "Dead Air" Spaces for more information.

**NOTE:** For any location, make sure no door or other obstruction could keep carbon monoxide or smoke from reaching the Alarm.

## Installing Smoke/CO Alarms in Mobile Homes

For minimum security install one Smoke/CO Alarm as close to each sleeping area as possible. For more security, put one unit in each room. Many older mobile homes (especially those built before 1978) have little or no insulation. If your mobile home is not well insulated, or if you are unsure of the amount of insulation, it is important to install units on inside walls only.

# Where to Install (Continued)

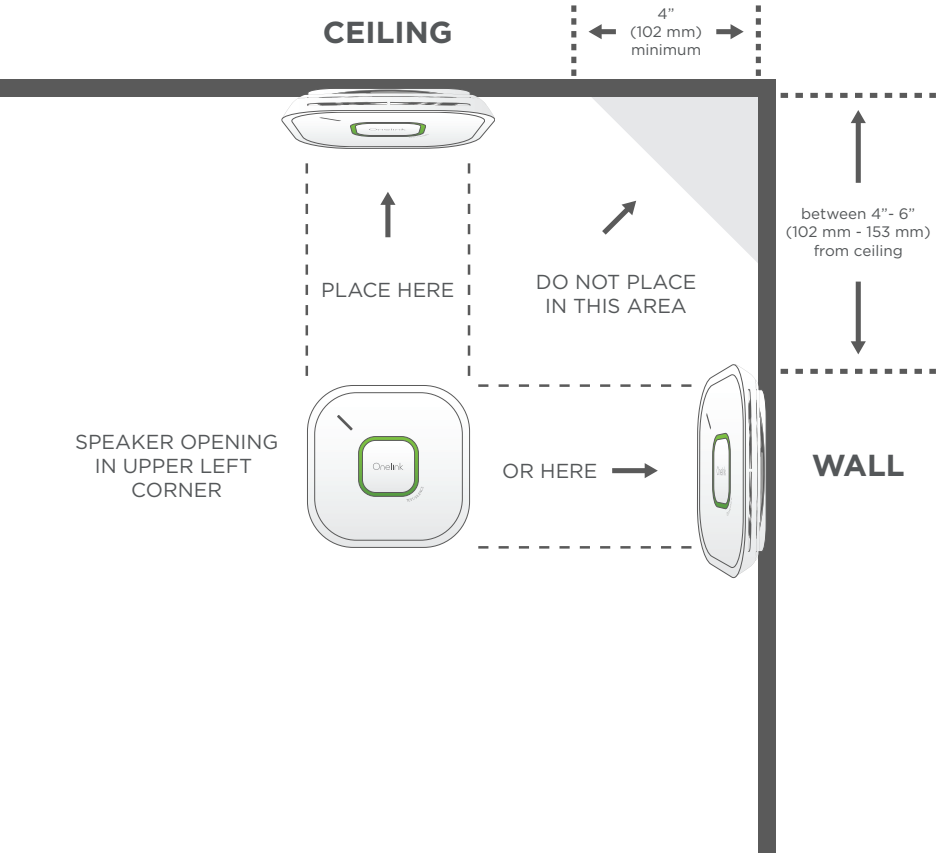

# Where Not to Install

## Do NOT locate this Smoke/CO Alarm:

- In garages, furnace rooms, crawl spaces and unfinished attics. Avoid extremely dusty, dirty or greasy areas.
- Where combustion particles are produced. Combustion particles form when something burns. Areas to avoid include poorly ventilated kitchens, garages, and furnace rooms. Keep units at least 20 feet (6 meters) from the sources of combustion particles (stove, furnace, water heater, space heater) if possible. In areas where a 20 foot (6 meter) distance is not possible – in modular, mobile, or smaller homes, for example – it is recommended the Smoke Alarm be placed as far from these fuel-burning sources as possible. The placement recommendations are intended to keep these Alarms at a reasonable distance from a fuel-burning source, and thus reduce “unwanted” alarms. Unwanted alarms can occur if a Smoke Alarm is placed directly next to a fuel-burning source. Ventilate these areas as much as possible.
- Within 5 feet (1.5 meters) of any cooking appliance. In air streams near kitchens. Air currents can draw cooking smoke into the smoke sensor and cause unwanted alarms.
- In extremely humid areas. This Alarm should be at least 10 feet (3 meters) from a shower, sauna, humidifier, vaporizer, dishwasher, laundry room, utility room, or other source of high humidity.
- In direct sunlight.
- In turbulent air, near ceiling fans or open windows. Blowing air may prevent CO/smoke from reaching the sensors.
- In areas where temperature is colder than 40° F (4.4°C) or hotter than 100° F (37.8°C). These areas include non air conditioned crawl spaces, unfinished attics, uninsulated or poorly insulated ceilings, porches, and garages.
- In insect infested areas. Insects can clog the openings to sensing chamber.
- Less than 12 inches (305 mm) away from fluorescent lights. Electrical “noise” can interfere with the sensor.
- In “dead air” spaces. See below for additional information.

## Installing Smoke/CO Alarms in Mobile Homes

“Dead air” spaces may prevent smoke from reaching the Smoke/CO Alarm. To avoid dead air spaces, follow installation recommendations below.

- On ceilings, install Smoke/CO Alarms as close to the center of the ceiling as possible. If this is not possible, install the Smoke/CO Alarm at least 4 inches (102 mm) from the wall or corner.
- For wall mounting (if allowed by building codes), the top edge of Smoke/CO Alarms should be placed between 4 inches (102 mm) and 6 inches (153 mm) from the wall/ceiling line, below typical “dead air” spaces.
- On a peaked, gabled, or cathedral ceiling, install first Smoke/CO Alarm within 3 feet (0.9 meters) of the peak of the ceiling, measured horizontally. Additional Smoke/CO Alarms may be required depending on the length, angle, etc. of the ceiling’s slope. Refer to NFPA 72 for details on requirements for sloped or peaked ceilings.



# Set-Up & Installation



**DANGER: ELECTRICAL SHOCK HAZARD.** Turn off power to the area where you will install this unit at the circuit breaker or fuse box before beginning installation. Failure to turn off the power before installation may result in serious electrical shock, injury or death



**IMPORTANT:** The top edge of the Alarm **MUST** be between 4 and 6 inches down from the ceiling. When wall mounting, the speaker opening is in the upper left corner, as indicated by the illustration below.

## Tools you will need:

- Needle-nose pliers or utility knife
- Standard phillips screwdriver
- Wire strippers

Ensure the iOS software is updated to iOS 10 or later or Android 5 or later.

**Step 1** Download the free Onelink app from the App Store or Google Play and follow set-up instructions.

**Step 2** Attach the mounting bracket to the junction box.

**Step 3** Using wire nuts, connect the power connector to the household wiring.

If any unit in the series does not alarm with the test button, **TURN OFF POWER** and recheck connections. If it does not alarm with the test button when you restore power, replace it immediately.

Improper wiring of the power connector or the wiring leading to the power connector will cause damage to the Alarm and may lead to a non-functioning Alarm.

**NOTE:** Electrical ratings: 120V AC 60 Hz, 0.065 A 3.0 Lithium Battery Backup

**Speaker  
Opening**



## Set-Up & Installation (Continued)

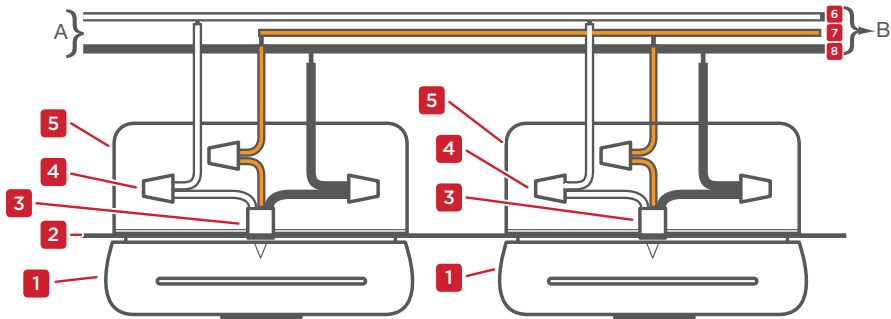

1. Smoke/CO Alarm	2. Ceiling or Wall
3. Power Connector	4. Wire Nut
5. Junction Box	6. Neutral Wire (white)
7. Interconnect Wire (orange)	8. Hot Wire (black)

# Set-Up & Installation (Continued)

## Interconnected units must meet ALL of the following requirements:

- A maximum of 18 compatible units may be interconnected (Maximum of 12 Smoke Alarms).
- The same fuse or circuit breaker must power all interconnected units.
- The total length of wire interconnecting the units should be less than 1000 feet (300 meters). This type of wire is commonly available at Hardware and Electrical Supply stores.
- All wiring must conform to all local electrical codes and NFPA 70 (NEC). Refer to NFPA 72, NFPA 101, and/or your local building code for further connection requirements.

## Stand-Alone Alarm Only:

- Connect the white wire on the power connector to the neutral wire in the junction box.
- Connect the black wire on the power connector to the hot wire in the junction box.
- Tuck the orange wire inside the junction box. It is used for interconnect only.

## Interconnect Units Only:



**IMPORTANT FEATURE:** I042135 is compatible with all First Alert and BRK hardwired alarm models.

Strip off about 1/2" (12 mm) of the plastic coating on the orange wire on the power connector.

- Connect the white wire on the power connector to the neutral wire in the junction box.
- Connect the black wire on the power connector to the hot wire in the junction box.
- Connect the orange wire on the power connector to the interconnect wire in the junction box. Repeat for each unit you are interconnecting. Never connect the hot or neutral wires in the junction box to the orange interconnect wire. Never cross hot and neutral wires between Alarms.



**WARNING:** Improper wiring of the power connector or the wiring leading to the power connector will cause damage to the Alarm and may lead to a non-functioning Alarm.

If you need to remove the power connector, turn POWER OFF first. Insert a flat screwdriver blade between the power connector and the security tab inside the power input block. Gently pry back the tab and pull the connector free.

**Step 4** Plug the power connector into the back of the alarm.

# Set-Up & Installation (Continued)

- Step 5** Position the base of the Alarm over the mounting bracket, and turn the alarm clockwise(right) until the unit is in its place. This activates the battery back-up. Once unit is activated, it can not be turned off.

**NOTE:** After you activate the Alarm, the Color Indicator Ring will power up and the Alarm will welcome you. To program your alarm, follow the instructions provided in the Onelink app.



**WARNING:** iOS and Android device notifications require a functional Wireless connection. For best results, recommended to use with a 802.11 b/g/n/ac router. The notifications are only as reliable as your Wireless network and are not a substitute for a third party emergency monitoring service.

This Smoke/CO Alarm is designed to be mounted on any standard wiring junction box up to a 4-inch (10 cm) size, on either the ceiling or wall (if allowed by local codes). Read "Where to Install This Alarm" and "Where This Alarm Should Not Be Installed" before you begin installation.

## STAND-ALONE ALARM ONLY:

- If you are only installing one Smoke Alarm, restore power to the junction box.

## INTERCONNECTED UNITS ONLY:

- If you are interconnecting multiple Smoke Alarms, repeat steps 1-5 for each Smoke Alarm in the series. When you are finished, restore power to the junction box.



**WARNING:** Make sure the Alarm is not receiving excessively noisy power. Examples of noisy power could be major appliances on the same circuit, power from a generator or solar power, light dimmer on the same circuit or mounted near fluorescent lighting. Excessively noisy power may cause damage to your Alarm.

# Installation of Adapter Plug

**NOTE:** Adapter plugs may not be included in all SKUs.

## Installation Instructions:

**Step 1** Verify which COMPATIBLE MODELS are installed in your system to determine the Adapter Plug to use.

## Compatible Models:

All of the following BRK/Kidde® / Fyrnetics® / Lifesaver® / Firex Alarms are compatible with 1042135 Alarm, and can be interconnected using the appropriate Adapter Plug. Visit [www.firstalert.com/product/onelinksmokeco](http://www.firstalert.com/product/onelinksmokeco) to view alarms compatible with Onelink Smart Smoke & Carbon Monoxide Alarm.

## First Alert® / BRK® Alarms



**IMPORTANT FEATURE:** 1042135 is compatible with all First Alert and BRK hardwired alarm models.

**NOTE:** Adapter Plug can be used on Firex® Models manufactured on or before January 1, 2005.

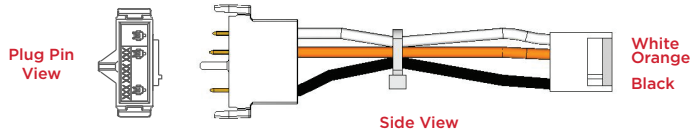

**NOTE:** Twist tie should not be removed.

# Installation of Adapter Plug (Continued)



**WARNING:** Installation of this unit must conform to the electrical codes in your area; Article 760 of NFPA 70 (NEC), NFPA 72, NFPA 101; SBC (SBCCI); UBC (ICBO); NBC (BOCA); OTFDC (CABO), and any other local or building codes that may apply. Wiring and installation must be performed by a licensed electrician. Failure to follow these guidelines may result in injury or property damage. This unit must be powered by a 24-hour, 120VAC pure sine wave 60Hz circuit. Be sure the circuit cannot be turned off by a switch, dimmer, or ground fault circuit interrupter. Failure to connect this unit to a 24-hour circuit may prevent it from providing constant protection.

- Step 2** Turn off AC power.
- Step 3** Install new mounting bracket.
- Step 4** Using wire nuts, connect the power connector to the household wiring.
- Step 5** Connect the black end of the appropriate Adapter Plug to the existing power connector.

**NOTE:** There may not be enough room for the Adapter Plug and additional wiring to fit in the junction box. If not, the old power connector must be removed and replaced with the BRK<sup>®</sup> Power Connector.

- Step 6** Connect the other end of the Adapter Plug to First Alert<sup>®</sup> / BRK<sup>®</sup> Alarm.
- Step 7** Check all connections. Make sure all plugs are completely connected and snapped together. Ensure the Adapter Plug is securely connected to the existing Power Connector.
- Step 8** Install the base of the Alarm to the mounting bracket.
- Step 9** Restore power to the junction box.
- Step 10** Test each Alarm. Press and hold the test button until the unit alarms. When testing a series of interconnected units you must test each unit individually. Make sure all units alarm when each one is tested.

# Installation of Adapter Plug (Continued)



**DANGER:** If any unit in the series does not alarm, **TURN OFF POWER** and recheck connections. **RESTORE POWER.** If any unit within interconnected alarms does not alarm, replace it immediately.

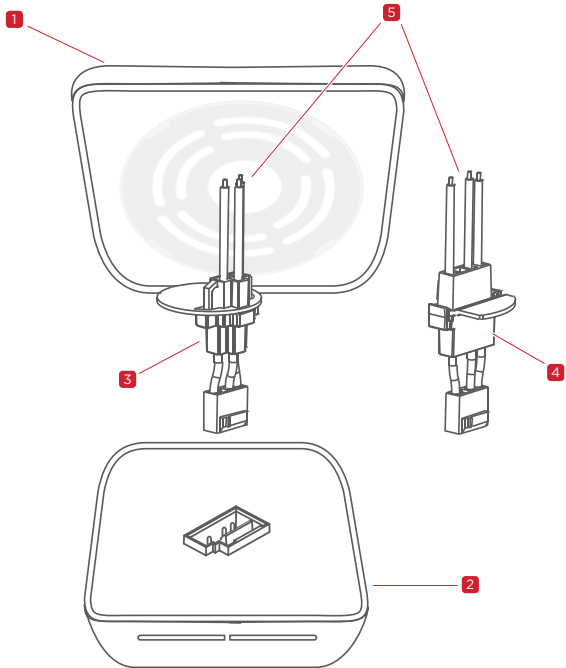

1. Mounting Bracket

2. First Alert® / BRK® Alarm

3. Kidde® Adapter

4. Firex® Adapter

5. Existing compatible power connector

**Electrical Rating:**

120V AC, 100mA Maximum  
Not for Current Interruption

# Installation of Adapter Plug (Continued)



**IMPORTANT:** Interconnect units within a single family residence only. Otherwise all households will experience unwanted alarms when you test any unit in the series. Interconnected units will only work if they are wired to compatible units and all requirements are met. This unit is designed to be compatible with First Alert® and BRK Electronics® Models listed in the User's Manual.

## Interconnected units must meet ALL of the following requirements:

- A maximum of 18 compatible units may be interconnected (Maximum of 12 Smoke Alarms - **Except Firex® models PG-40 and G-6**).
- The same fuse or circuit breaker must power all interconnected units.
- The total length of wire interconnecting the units should be less than 1000 feet (300 meters). The interconnect wire should be #18 gauge or larger, rated at least 300V. If an interconnect wire is not already part of your household wiring, you will need to install one. This type of wire is commonly available at Hardware and Electrical Supply stores.
- All wiring must conform to all local electrical codes and Article 760 of NFPA 70 (NEC). Refer to NFPA 72, NFPA 101, and/or your local building code for further connection requirements.



**WARNING:** Failure to meet any of the above requirements could damage the units and cause them to malfunction, removing your protection. AC and AC/DC Alarms can be interconnected. Under AC power, all units will alarm when one senses smoke. When power is interrupted, only the AC/DC units in the series will continue to send and receive signals. AC powered Alarms will not operate.

# Wireless Interconnect

## Benefits of Wireless Interconnect

The wireless interconnect feature on this alarm allows you to connect each of your First Alert Onelink alarms so when one alarm sounds, they all will sound.



**WARNING:** Install alarms and test to assure range and reliability of interconnection throughout the house.

- First Alert Onelink alarms can typically communicate with each other if they're 50ft (15m) apart inside a home. Keep in mind that some features of a home may reduce the interconnect range and reliability of interconnection, including the number of floors, number/size of rooms, furniture, type of building material, suspended ceilings, ductwork, large metallic appliances and metal studs. This kind of interference may be fixed by adding more Onelink alarms that can route wireless signals around any various obstructions.
- Make sure you test your Onelink alarms for proper interconnection via the weekly testing.



# Wireless Interconnect (Continued)

## Wireless Frequency

This alarm supports wireless frequency of 2.4Ghz, 802.11 b/g/n/ac router required.

## Adding Additional Alarms

Simply follow the instructions on your Onelink app to add additional alarms to your account.

## Identification of Events

If your alarm sounds, it is important to first identify the type of alarm.

# When the Alarm Sounds

## What To Do If The Smoke Alarm Sounds

- If the unit alarms and you are not testing the unit, it is warning you of a potentially dangerous situation that requires your immediate attention. NEVER ignore any alarm. Ignoring the alarm may result in injury or death.
- If the unit alarms get everyone out of the house immediately.

## What To Do In Case of a Fire

- Don't panic; stay clam. Follow your family escape plan.
- Get out of the house as quickly as possible. Don't stop to get dressed or collect anything.
- Feel doors with the back of your hand before opening them. If a door is cool, open it slowly. Don't open a hot door. Keep doors and windows closed, unless you must escape through them.
- Cover your nose and mouth with a cloth (preferably damp). Take short, shallow breaths.
- Meet at your planned meeting place outside your home, and do a head count to make sure everybody got out safely. Call the Fire Department as soon as possible from outside. Give your address, then your name.
- Never go back inside a burning building for any reason.
- Contact your Fire Department for ideas on making your home safer.

## What To Do If The CO Alarm Sounds

1. Press the Test/Silence button (On App or on unit).
2. Call your emergency services, fire department or 911.
3. Immediately move to fresh air—outdoors or by an open door or window. Do a head count to check that all persons are accounted for. Do not re-enter the premises, or move away from the open door or window until the emergency services responder has arrived, the premises have been aired out, and your CO Alarm remains in its normal condition.

# When the Alarm Sounds (Continued)

- After following steps 1-3, if your CO Alarm reactivates within a 24-hour period, repeat steps 1-3 and call a qualified appliance technician to investigate for sources of CO from fuel-burning equipment and appliances, and inspect for proper operation of this equipment. If problems are identified during this inspection have the equipment serviced immediately. Note any combustion equipment not inspected by the technician, and consult the manufacturers' instructions, or contact the manufacturers directly, for more information about CO safety and this equipment. Make sure that motor vehicles are not, and have not, been operating in an attached garage or adjacent to the residence.

**NOTE:** A qualified appliance technician is defined as "a person, firm, corporation, or company that either in person or through a representative, is engaged in and responsible for the installation, testing, servicing, or replacement of heating, ventilation, air conditioning (HVAC) equipment, combustion appliances and equipment, and/or gas fireplaces or other decorative combustion equipment."



**WARNING:** Actuation of this device indicates the presence of carbon monoxide (CO) which can KILL YOU. If alarm signal sounds (description of alarm signal, eg four beeps): (1) immediately move to fresh air outdoors or by an open window, check that all persons are accounted for. Do not reenter the premise or move away from the open door/window until the emergency service responders have arrived, the premises have been aired out, and your alarm remains in its normal condition; (2) call you emergency local service (telephone number) (fire department or 911) (ii) If "service" signal sounds (description of the trouble signal eg. one beep)

# Using the Silence Feature

## The Silence Feature

This feature is intended to temporarily silence the horn while you identify and correct the problem. Do not use the Silence Feature in emergency situations. It will not correct a CO problem or extinguish a fire. The Silence Feature can temporarily quiet an unwanted alarm for several minutes. You can silence this Smoke/CO Alarm by pressing the Test/Silence button on the alarm cover for at least 3-5 seconds or via the Onelink app. After the Test/Silence button is released, the Red LED stops during the silence mode.

## Silence the End of Life Signal

This silence feature can temporarily quiet the End of Life warning "chirp" for up to 2 days. You can silence the End of Life warning "chirp" by pressing the Test/Silence button or via the Onelink app. The horn will chirp, acknowledging that the End of Life silence feature has been activated. After approximately 2 days, the End of Life "chirp" will resume.



**WARNING:** Never deactivate the unit to quiet an unwanted alarm. Deactivating the alarm disables the unit and removes your protection.

When the Smoke Alarm is Silenced	When the CO Alarm is Silenced
The Smoke Alarm will remain silent for up to 15 minutes, then return to normal operation.	The CO Alarm will remain silent for up to 4 minutes.
If the smoke has not cleared or continues to increase, the device will go back into alarm.	After 4 minutes, if CO levels remain potentially dangerous, the horn will start sounding again.

# Weekly Testing



**WARNING:** NEVER use an open flame of any kind to test this unit. You might accidentally damage or set fire to the unit or to your home. NEVER use vehicle exhaust! Exhaust may cause permanent damage and voids your warranty.



**WARNING:** DO NOT stand close to the Alarm when the horn is sounding. Exposure at close range may be harmful to your hearing. When testing, step away when horn starts sounding.



**CAUTION:** It is important to test this unit every week to make sure it is working properly. Using the test button is the recommended way to test this Smoke/CO Alarm.



**WARNING:** Test device operation after vehicle has been in storage, before each trip, and at least once per week during use.

You can test this Smoke/CO Alarm by pressing and holding the Test/Silence button on the Alarm cover until Alarm Voice says "Testing" (typically 3-5 seconds).

## During testing, you will see and hear the following sequence:

- "The Alarm Voice will say "Testing Alarms... The Alarm will sound and for your protection is very loud. This may take a few seconds." The LED chases Blue. The Alarm Voice will say "Testing Smoke." The Horn will sound 3 beeps, twice. The LED chases and flashes Red. The Alarm Voice will say "Evacuate, Evacuate, there's Fire in the [Location. Example: "Kitchen"]." The LED flashes green."
- "Next, the Alarm Voice will say "Testing Carbon Monoxide." The Horn will sound 4 beeps, twice. The LED chases and flashes Red. The Alarm Voice will say "Evacuate, Evacuate, there's Carbon Monoxide in the [Location. Example: "Kitchen"]." The LED flashes green. The Alarm Voice will say "Highest carbon monoxide level was 0 PPM." The LED chases Blue. The Alarm Voice will then say "The testing is almost complete." After a pause, the Alarm Voice will say "The test is done, and you are protected." The LED flashes green.

If the unit does not alarm, make sure it has been activated correctly, and test again. If the unit still does not alarm, replace it immediately.

# Regular Maintenance

This unit has been designed to be as maintenance-free as possible, but there are a few simple things you must do to keep it working properly:

- Test it at least once a week.
- Clean the Smoke/CO Alarm at least once a month; gently vacuum the outside of the Smoke/CO Alarm using your household vacuum's soft brush attachment. A can of clean compressed air (sold at computer or office supply stores) may also be used. Follow manufacturer instructions for use. Test the Smoke/CO Alarm. Never use water, cleaners or solvents since they may damage the unit.
- If the Smoke/CO Alarm becomes contaminated by excessive dirt, dust and/or grime, and cannot be cleaned to avoid unwanted alarms, replace the unit immediately.
- Relocate the unit if it sounds frequent unwanted alarms. See "Where This Alarm Should Not Be Installed" for details.



**IMPORTANT:** Actual battery service life depends on the Smoke/CO Alarm and the environment in which it is installed. Regardless of the manufacturer's suggested battery life, you **MUST** replace the Alarm immediately once the unit starts "chirping" (the "low battery warning").

## Alarm End of Life

### Permanently Deactivating the Alarm

After 10 years of operation or low battery warning, deactivate the Alarm by following the diagram below: Score label on dotted line and move switch all the way to the right to DEACTIVATE mode.

**NOTE:** At end of life or low battery indication (chirp): unit must be put into deactivation mode to deactivate remaining stored energy in battery. Unit will no longer function once put into this mode. Unit will resist re-mounting. Once deactivated, replace Alarm immediately.



1

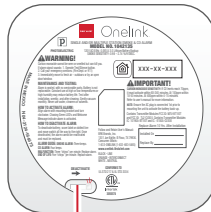

2

1. Score label on dotted line
2. Slide switch to the right

# Ionization & Photoelectric Technology

This alarm uses Photoelectric technology.

All First Alert® Onelink® Smoke Alarms conform to regulatory requirements, including UL217 and are designed to detect particles of combustion. Smoke particles of varying number and size are produced in all fires.

## Ionization Technology



Ionization technology is generally more sensitive than Photoelectric technology at detecting small particles, which tend to be produced in greater amounts by flaming fires, which consume combustible materials rapidly and spread quickly. Sources of these fires may include paper burning in a wastebasket, or a grease fire in the kitchen.

## Photoelectric Technology



Photoelectric technology is generally more sensitive than ionization technology at detecting large particles, which tend to be produced in greater amounts by smoldering fires, which may smolder for hours before bursting into flame. Sources of these fires may include cigarettes burning in couches or bedding.

**NOTE:** For maximum protection, use both types of Smoke Alarms on each level and in every bedroom of your home.

# Fire Safety Tips

## Follow safety rules and prevent hazardous situations:

1. Use smoking materials properly. Never smoke in bed.
2. Keep matches or lighters away from children.
3. Store flammable materials in proper containers.
4. Keep electrical appliances in good condition and don't overload electrical circuits.
5. Keep stoves, barbecue grills, fireplaces and chimneys grease-free and debris-free.
6. Never leave anything cooking on the stove unattended.
7. Keep portable heaters and open flames, like candles, away from flammable materials.
8. Don't let rubbish accumulate.

# Fire Safety Tips (Continued)

## Basic Safety Information

Keep alarms clean, and test them weekly. Replace alarms immediately if they are not working properly. Smoke alarms that do not work cannot alert you to a fire. Keep at least one working fire extinguisher on every floor, and an additional one in the kitchen. Have fire escape ladders or other reliable means of escape from an upper floor in case stairs are blocked.



**IMPORTANT:** Dangers, Warnings and Cautions alert you to important operating instructions or to potentially hazardous situations. Pay special attention to these items. This Smoke/CO Alarm is approved for use in single-family residences. It is NOT designed for marine or RV use.



**CAUTION:** This combination Smoke/Carbon Monoxide Alarm has two separate alarms. The CO Alarm is not designed to detect fire or any other gas. It will only indicate the presence of carbon monoxide gas at the sensor. Carbon monoxide gas may be present in other areas. The Smoke Alarm will only indicate the presence of smoke that reaches the sensor. The Smoke Alarm is not designed to sense gas, heat or flames.



**WARNING:** This unit will not operate without battery power. The Smoke/CO Alarm cannot work until you activate the battery power pack. NEVER ignore any alarm. See "What To Do If Your Smoke/Co Alarm Sounds" on page 11 for more information on how to respond to an alarm. Failure to respond can result in injury or death. The Silence Features are for your convenience only and will not correct a problem. See "Using the Silence Feature" on page 12 for details. Always check your home for a potential problem after any alarm. Failure to do so can result in injury or death. Test this Smoke/CO Alarm once a week. If the alarm ever fails to test correctly, have it replaced immediately! If the alarm is not working properly, it cannot alert you to a problem. This product is intended for use in ordinary indoor locations of family living units. It is not designed to measure CO levels in compliance with Occupational Safety and Health Administration (OSHA) commercial or industrial standards. Individuals with medical conditions that may make them more sensitive to carbon monoxide may consider using warning devices which provide audible and visual signals for carbon monoxide concentrations under 30ppm. For additional information on carbon monoxide and your medical condition, contact your physician.



**CAUTION:** This device is designed to protect individuals from the acute effects of carbon monoxide exposure. It will not fully safeguard individuals with specific medical conditions. If in doubt, consult medical practitioner.



**WARNING:** This product is intended for use in ordinary indoor residential areas. It is not designed to measure compliance with commercial and industrial standards.

# What You Need to Know About CO

## What is CO?

CO is an invisible, odorless, tasteless gas produced when fossil fuels do not burn completely, or are exposed to heat (usually fire). Electrical appliances typically do not produce CO.

**These fuels include:** Wood, coal, charcoal, oil, natural gas, gasoline, kerosene, and propane.

Common appliances are often sources of CO. If they are not properly maintained, are improperly ventilated, or malfunction, CO levels can rise quickly. CO is a real danger now that homes are more energy efficient. "Air-tight" homes with added insulation, sealed windows, and other weatherproofing can "trap" CO inside.

## Symptoms of CO Poisoning

The following symptoms may be related to CARBON MONOXIDE POISONING and should be discussed with ALL members of the household:

**Mild exposure:** Headaches, running nose, sore eyes, often described as "flu"-like symptoms;

**Medium Exposure:** Dizziness, drowsiness, vomiting;

**Extreme Exposure:** : unconsciousness, brain damage, death.

Many cases of reported CARBON MONOXIDE POISONING indicate that while victims are aware they are not well, they become so disoriented they are unable to save themselves by either exiting the building or calling for assistance.



**IMPORTANT:** This CO Alarm measures exposure to CO over time. It alarms if CO levels are extremely high in a short period of time, or if CO levels reach a certain minimum over a long period of time. The CO Alarm generally sounds an alarm before the onset of symptoms in average, healthy adults. Why is this important? Because you need to be warned of a potential CO problem while you can still react in time. In many reported cases of CO exposure, victims may be aware that they are not feeling well, but become disoriented and can no longer react well enough to exit the building or get help. Also, young children and pets may be the first affected. The average healthy adult might not feel any symptoms when the CO Alarm sounds. However, people with cardiac or respiratory problems, infants, unborn babies, pregnant mothers, or elderly people can be more quickly and severely affected by CO. If you experience even mild symptoms of CO poisoning, consult your doctor immediately!

## Finding the Source of CO After an Alarm

Carbon monoxide is an odorless, invisible gas, which often makes it difficult to locate the source of CO after an alarm. These are a few of the factors that can make it difficult to locate sources of CO:

- House well ventilated before the investigator arrives.
- Problem caused by "backdrafting."
- Transient CO problem caused by special circumstances.

Because CO may dissipate by the time an investigator arrives, it may be difficult to locate the source of CO.

***BRK Brands, Inc. shall not be obligated to pay for any carbon monoxide investigation or service call.***

# Potential Sources of CO in the Home

**Fuel-Burning Appliances:** Like portable heater, gas or wood burning fireplace, gas kitchen range or cooktop, gas clothes dryer.

**Damaged or Insufficient Venting:** Corroded or disconnected water heater vent pipe, leaking chimney pipe or flue, or cracked heat exchanger, blocked or clogged chimney opening.

**Improper Use of Appliance/Device:** Operating a barbecue grill or vehicle in an enclosed area (like a garage or screened porch).

**Transient CO Problems:** “Transient” or on-again-off-again CO problems can be caused by outdoor conditions and other special circumstances. The following conditions can result in transient CO situations:

1. Excessive spillage or reverse venting of fuel appliances caused by outdoor conditions such as:
  - Wind direction and/or velocity, including high, gusty winds. Heavy air in the vent pipes (cold/humid air with extended periods between cycles).
  - Negative pressure differential resulting from the use of exhaust fans.
  - Several appliances running at the same time competing for limited fresh air.
  - Vent pipe connections vibrating loose from clothes dryers, furnaces, or water heaters.
  - Obstructions in or unconventional vent pipe designs which can amplify the above situations.
2. Extended operation of unvented fuel burning devices (range, oven, fireplace).
3. Temperature inversions, which can trap exhaust close to the ground.
4. Car idling in an open or closed attached garage, or near a home.

These conditions are dangerous because they can trap exhaust in your home. Since these conditions can come and go, they are also hard to recreate during a CO investigation.



# Potential Sources of CO in the Home (Continued)

## How Can I Protect My Family From CO Poisoning?

A CO Alarm is an excellent means of protection. It monitors the air and sounds a loud alarm before Carbon Monoxide levels become threatening for average, healthy adults.

### **A CO Alarm is not a substitute for proper maintenance of home appliances.**

To help prevent CO problems and reduce the risk of CO poisoning:

- Clean chimneys and flues yearly. Keep them free of debris, leaves, and nests for proper air flow. Also, have a professional check for rust and corrosion, cracks, or separations. These conditions can prevent proper air movement and cause back-drafting. Never "cap" or cover a chimney in any way that would block air flow.
- Test and maintain all fuel-burning equipment annually. Many local gas or oil companies and HVAC companies offer appliance inspections for a nominal fee.
- Make regular visual inspections of all fuel-burning appliances. Check appliances for excessive rust and scaling. Also check the flame on the burner and pilot lights. The flame should be blue. A yellow flame means fuel is not being burned completely and CO may be present. Keep the blower door on the furnace closed. Use vents or fans when they are available on all fuel-burning appliances. Make sure appliances are vented to the outside. Do not grill or barbecue indoors, or in garages or onscreen porches.
- Check for exhaust back-flow from CO sources. Check the draft hood on an operating furnace for a back-draft. Look for cracks on furnace heat exchangers.
- Check the house or garage on the other side of shared wall.
- Keep windows and doors open slightly. If you suspect that CO is escaping into your home, open a window or a door. Opening windows and doors can significantly decrease CO levels.

# Regulatory Information for CO Alarms

## What Levels of CO Cause an Alarm?

Underwriters Laboratories Inc. Standard UL2034 requires residential CO Alarms to sound when exposed to levels of CO and exposure times as described below. They are measured in parts per million (ppm) of CO over time (in minutes).

### UL2034 Required Alarm Points\*:

- If the alarm is exposed to 400 ppm of CO, IT MUST ALARM BETWEEN 4 & 15 MINUTES.
- If the alarm is exposed to 150 ppm of CO, IT MUST ALARM BETWEEN 10 & 50 MINUTES.
- If the alarm is exposed to 70 ppm of CO, IT MUST ALARM BETWEEN 60 & 240 MINUTES.  
\*Approximately 10% of COHb exposure at levels of 10% to 95% Relative Humidity (RH).

This unit is designed not to alarm when exposed to a constant level of 30 ppm for 30 days.



**IMPORTANT:** CO alarms are designed to alarm before there is an immediate life threat. Since you cannot see or smell CO, never assume it's not present. An exposure to 100 ppm of CO for 20 minutes may not affect average, healthy adults but after 4 hours the same level may cause headaches. An exposure to 400 ppm of CO may cause headaches in average, healthy adults after 35 minutes, but can cause death after 2 hours.

## Standards

Underwriters Laboratories Inc. Single and Multiple Station carbon monoxide alarms UL2034. According to Underwriters Laboratories Inc. UL2034, Section 1-1.2: "Carbon monoxide alarms covered by these requirements are intended to respond to the presence of carbon monoxide from sources such as, but not limited to, exhaust from internal-combustion engines, abnormal operation of fuel-fired appliances, and fireplaces. CO Alarms are intended to alarm at carbon monoxide levels below those that could cause a loss of ability to react to the dangers of Carbon Monoxide exposure." This CO Alarm monitors the air at the Alarm, and is designed to alarm before CO levels become life threatening. This allows you precious time to leave the house and correct the problem. This is only possible if Alarms are located, installed, and maintained as described in this manual.

## Gas Detection at Typical Temperature and Humidity Ranges

The CO Alarm is not formulated to detect CO levels below 30 ppm typically. Tested for false alarm resistance to Methane (500 ppm), Butane (300 ppm), Heptane (500 ppm), Ethyl Acetate (200 ppm), Isopropyl Alcohol (200 ppm) and Carbon Dioxide (5000 ppm). Values measure gas and vapor concentrations in parts per million.

## Audible Alarm

85 dB minimum at 10 feet (3 meters).

# Regulatory Information for Smoke Alarms

## Installing Smoke Alarms in Single-Family Residences

The National Fire Protection Association (NFPA), recommends one Smoke Alarm on every floor, in every sleeping area, and in every bedroom. In new construction, the Smoke Alarms must be AC powered and interconnected. See "Agency Placement Recommendations" for details. For additional coverage, it is recommended that you install a Smoke Alarm in all rooms, halls, storage areas, finished attics, and basements, where temperatures normally remain between 40° F (4.4° C) and 100° F (37.8° C). Make sure no door or other obstruction could keep smoke from reaching the Smoke Alarms.

For your information, the National Fire Alarm and Signaling Code, NFPA 72, reads as follows:

Required Detection. Where required by applicable laws, codes, or standards for a specific type of occupancy, approved single- and multiple-station smoke alarms shall be installed as follows:

- In all sleeping rooms and guest rooms
- Outside of each separate dwelling unit sleeping area, within 21 ft (6.4 m) of any door to a sleeping room, the distance measured along a path of travel
- On every level of a dwelling unit, including basements
- On every level of a residential board and care occupancy (small facility), including basements and excluding crawl spaces and unfinished attics
- In the living area(s) of a guest suite In the living area(s) of a residential board and care occupancy



**IMPORTANT:** Specific requirements for Smoke Alarm installation vary from state to state and from region to region. Check with your local Fire Department for current requirements in your area. It is recommended AC or AC/DC units be interconnected for added protection.

## Recommended Placement



### Smoke Alarm

One on every level and in every bedroom



### Carbon Monoxide

One on every level and in every bedroom



### Fire Extinguisher

One on every level, plus kitchen and garage

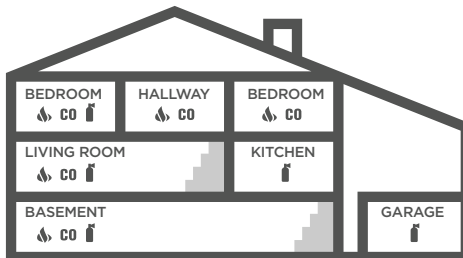

# Regulatory Information

## Federal Communications Commission (FCC) Compliance Statement

**NOTE:** This equipment has been tested and found to comply with the limits for a Class B digital device, pursuant to Part 15 of the FCC Rules. These limits are designed to provide reasonable protection against harmful interference in a residential installation. This equipment generates, uses and can radiate radio frequency energy and, if not installed and used in accordance with the instructions, may cause harmful interference to radio communications. However, there is no guarantee that interference will not occur in a particular installation. If this equipment does cause harmful interference to radio or television reception, which can be determined by turning the equipment off and on, the user is encouraged to try to correct the interference by one or more of the following measures:

- Reorient or relocate the receiving antenna.
- Increase the separation between the equipment and receiver.
- Connect the equipment into an outlet on a circuit different from that to which the receiver is connected.
- Consult the dealer or an experienced radio/TV technician for help.



**WARNING:** Changes or modifications to this unit not expressly approved by the party responsible for compliance could void the user's authority to operate the equipment.

This device complies with Part 15 of the FCC Rules. Operation is subject to the following two conditions: (1) this device may not cause harmful interference, and (2) this device must accept any interference received, including interference that may cause undesired operation.

**RF Exposure Information:** This equipment complies with FCC radiation exposure limits set forth for an uncontrolled environment. In order to avoid the possibility of exceeding the FCC radio frequency exposure limits, human proximity to the antenna shall not be less than 20cm during normal operation.

# Industry Canada (IC) Compliance Statement

This device complies with Industry Canada License-exempt RSS standard(s). Operation is subject to the following two conditions: (1) this device may not cause interference, and (2) this device must accept any interference, including interference that may cause undesired operation of the device.

Under Industry Canada regulations, this radio transmitter may only operate using an antenna of a type and maximum (or lesser) gain approved for the transmitter by Industry Canada. To reduce potential radio interference to other users, the antenna type and its gain should be so chosen that the equivalent isotropically radiated power (e.i.r.p.) is not more than that necessary for successful communication.

# Modular Devices FCC and Industry Canada Compliance Statements

## OEM Responsibilities to comply with FCC and Industry Canada Regulations

The BLEMOD1 Module and AW-CU300 Module have been certified for integration into products only by OEM integrators under the following condition:

1. The transmitter module must not be co-located or operating in conjunction with any other antenna or transmitter.

As long as the condition above is met, further transmitter testing will not be required. However, the OEM integrator is still responsible for testing their end-product for any additional compliance requirements required with this module installed (for example, digital device emissions, PC peripheral requirements, etc.).



**IMPORTANT:** In the event that these conditions cannot be met (for certain configurations or co-location with another transmitter), then the FCC and Industry Canada authorizations are no longer considered valid and the FCC ID and IC Certification Number cannot be used on the final product. In these circumstances, the OEM integrator will be responsible for re-evaluating the end product (including the transmitter) and obtaining a separate FCC and Industry Canada authorization.

## End Product Labeling

The BLEMOD1 Module and AW-CU300 Module are labeled with their own FCC ID and IC Certification Number. If the FCC ID and IC Certification Numbers are not visible when the module is installed inside another device, then the outside of the device into which the module is installed must also display a label referring to the enclosed module. In that case, the final end product must be labeled in a visible area with the following:

"Contains Transmitter Modules FCC ID: M7U-BT110T and FCC ID: TLZ-CU300"

"Contains Transmitter Modules IC: 10190A-BT110T and IC: 6100A-CU300"

Or

"Contains FCC ID: M7U-BT110T and FCC ID: TLZ-CU300"

"Contains IC: 10190A-BT110T and IC: 6100A-CU300"

The OEM of the BLEMOD1 Module and AW-CU300 Module must only use the approved antenna(s) listed above, which have been certified with this module. The OEM integrator has to be aware not to provide information to the end user regarding how to install or remove this RF module or change RF related parameters in the user manual of the end product.

To comply with FCC and Industry Canada RF radiation exposure limits for general population, the antenna(s) used for this transmitter must not be co-located or operating in conjunction with any other antenna or transmitter.

# Special Compliance Considerations

This Smoke Alarm is suitable for use in apartments, condominiums, townhouses, hospitals, day care facilities, health care facilities, boarding houses, group homes and dormitories provided a primary fire detection system already exists to meet fire detection requirements in common areas like lobbies, hallways, or porches. Using this Smoke Alarm in common areas may not provide sufficient warning to all residents or meet local fire protection ordinances/regulations.

This Smoke Alarm alone is not a suitable substitute for complete fire detection systems in places housing many people—like apartment buildings, condominiums, hotels, motels, dormitories, hospitals, health care facilities, nursing homes, day care facilities, or group homes of any kind. It is not a suitable substitute for complete fire detection systems in warehouses, industrial facilities, commercial buildings, and special-purpose non-residential buildings which require special fire detection and alarm systems. Depending on the building codes in your area, this Smoke Alarm may be used to provide additional protection in these facilities. In new construction, most building codes require the use of AC or AC/DC powered Smoke Alarms only. In existing construction, AC, AC/DC, or DC powered Smoke Alarms can be used as specified by local building codes. Refer to NFPA 72 (National Fire Alarm and Signaling Code) and NFPA 101 (Life Safety Code), local building codes, or consult your Fire Department for detailed fire protection requirements in buildings not defined as “households”.

**HUD MAP Program:** Certain HUD battery powered Smoke Alarm applications, especially those that fall under HUD 223(f) MAP (Multi-family Accelerated Processing), may require a 10 Year sealed tamper resistant battery. This alarm meets that requirement.



## General Limitations for Smoke/CO Alarms

This Smoke/CO Alarm is intended for residential use. It is not intended for use in industrial applications where Occupational Safety and Health Administration (OSHA) requirements for Carbon Monoxide Alarms must be met. The Smoke Alarm portion of this device is not intended to alert hearing impaired residents. Special purpose Smoke Alarms should be installed for hearing impaired residents (CO Alarms are not yet available for the hearing impaired).

**Smoke/CO Alarms may not waken all individuals.** Practice the escape plan at least twice a year, making sure that everyone is involved – from kids to grandparents. Allow children to master fire escape planning and practice before holding a fire drill at night when they are sleeping. If children or others do not readily waken to the sound of the Smoke/CO Alarm, or if there are infants or family members with mobility limitations, make sure that someone is assigned to assist them in fire drill and in the event of an emergency. It is recommended that you hold a fire drill while family members are sleeping in order to determine their response to the sound of the Smoke/CO Alarm while sleeping and to determine whether they may need assistance in the event of an emergency.

# General Limitations for Smoke/CO Alarms (Continued)

**Smoke/CO Alarms cannot work without power.** Battery operated units cannot work if the batteries are missing, disconnected or dead, if the wrong type of batteries are used, or if the batteries are not installed correctly. If the AC power is cut off for any reason (open fuse or circuit breaker, failure along a power line or at a power station, electrical fire that burns the electrical wires, etc.). If you are concerned about the limitations of battery or AC power, install both types of units.

**This Smoke/CO Alarm will not sense smoke or CO that does not reach the sensors.** It will only sense smoke or CO at the sensor. Smoke or CO may be present in other areas. Doors or other obstructions may affect the rate at which CO or smoke reaches the sensors. If bedroom doors are usually closed at night, we recommend you install an alarm device (Combination CO and Smoke Alarm, or separate CO Alarms and Smoke Alarms) in each bedroom and in the hallway between them.



**CAUTION:** This device will only indicate the presence of carbon monoxide gas at the sensor. Carbon monoxide gas may be present.

**This Smoke/CO Alarm may not sense smoke or CO on another level of the home.** Example: This alarm device, installed on the second floor, may not sense smoke or CO in the basement. For this reason, one alarm device may not give adequate early warning. Recommended minimum protection is one alarm device in every sleeping area, every bedroom, and on every level of your home. Some experts recommend battery powered Smoke and CO Alarms be used in conjunction with interconnected AC powered Smoke Alarms. For details, see “About Smoke Alarms” for details.

**Smoke/CO Alarms may not be heard.** The alarm horn loudness meets or exceeds current UL standards of 85 dB at 10 feet (3 meters). However, if the Smoke/CO Alarm is installed outside the bedroom, it may not wake up a sound sleeper or one who has recently used drugs or has been drinking alcoholic beverages. This is especially true if the door is closed or only partly open. Even persons who are awake may not hear the alarm horn if the sound is blocked by distance or closed doors. Noise from traffic, stereo, radio, television, air conditioner, or other appliances may also prevent alert persons from hearing the alarm horn. This Smoke/CO Alarm is not intended for people who are hearing impaired.

**The Alarm may not have time to alarm before the fire itself causes damage, injury, or death, since smoke from some fires may not reach the unit immediately. Examples of this include persons smoking in bed, children playing with matches, or fires caused by violent explosions resulting from escaping gas.**

**This Smoke/CO Alarm is not a substitute for life insurance.** Though this Smoke/CO Alarm warns against increasing CO levels or the presence of smoke, BRK Brands, Inc. does not warrant or imply in any way that they will protect lives. Homeowners and renters must still insure their lives.

**This Smoke/CO Alarm has a limited life.** Although this Smoke/CO Alarm and all of its parts have passed many stringent tests and are designed to be as reliable as possible, any of these parts could fail at any time. Therefore, you must test this device weekly. The unit should be replaced immediately if it is not operating properly.

This Smoke/CO Alarm is not foolproof. Like all other electronic devices, this Smoke/CO Alarm has limitations. It can only detect smoke or CO that reaches the sensors. It may not give early warning of the source of smoke or CO is in a remote part of the home, away from the alarm device.



# Troubleshooting Guide

App FAQ		
If the App...	Problem...	You Should...
Is unable to be downloaded or installed.	You cannot download or install the app.	Contact Customer Service Team.
Alarm FAQ		
If the Alarm...	Problem...	You Should...
Light flashes yellow and Horn sounds three "chirps" every minute. <b>Voice:</b> "Detector error. Please see manual or call customer service" every 5 hours.	<b>Malfunction Signal.</b> Device is not working properly and needs to be replaced.	Units under warranty should be returned to manufacturer for replacement. See "Limited Warranty" for details.
Horn sounds 5 "chirps" every minute.	<b>End of Life Signal.</b> Alarm needs to be replaced.	Immediately replace and deactivate the alarm.
White LED light turns off.	Alarm is running on battery back-up.	Check all connections or restore power.
Does not connect to your Wireless / Bluetooth or opportunity missed for pairing.	Alarm will not pair or you would like to reset the device to clear all settings.	Press the test button 5 times to reset alarm and try to pair to Wireless and Bluetooth again.
Carbon Monoxide Alarm ONLY:		
CO Alarm goes back into alarm 4 minutes after you Silence it.	CO levels indicate a potentially dangerous situation.	If you are feeling symptoms of CO poisoning, evacuate your home and call 911 or the Fire Department. Refer to "What To Do if the CO Alarm Sounds" on page 17 for details.
CO Alarm sounds frequently even though no high levels of CO are revealed in an investigation.	The CO Alarm may be improperly located. Refer to "Where to Install" on page 6 for details.	Relocate your Alarm. If frequent alarms continue, have home rechecked for potential CO problems. You may be experiencing an intermittent CO problem.
Smoke Alarm ONLY:		
Smoke Alarm sounds when no smoke is visible.	Unwanted alarm may be caused by non-emergency source like cooking smoke.	Silence alarm on App or using unit button; clean the alarm's cover with a soft, clean cloth. If frequent unwanted alarms continue, relocate your alarm. Alarm may be too close to kitchen, cooking appliance, or steamy bathroom.
<b>NOTE:</b> This alarm contains new Wireless and HomeKit technology that may not be wirelessly compatible with previously branded Onelink wireless alarms.		
If you have questions that cannot be answered by reading this manual, contact the Customer Service Team at <a href="mailto:onelinksupport@firstalert.com">onelinksupport@firstalert.com</a> or 1 (833) ONE-LINK (1-833-663-5465)		

# Limited Warranty

BRK Brands, Inc., (“BRK”) the maker of First Alert® brand products warrants that for a period of five years from the date of purchase, this product will be free from defects in material and workmanship. BRK, at its option, will repair or replace this product or any component of the product found to be defective during the warranty period. Replacement will be made with a new or re-manufactured product or component. If the product is no longer available, replacement may be made with a similar product of equal or greater value. This is your exclusive warranty. This warranty is valid for the original retail purchaser from the date of initial retail purchase and is not transferable. Keep the original sales receipt. Proof of purchase is required to obtain warranty performance. BRK dealers, service centers, or retail stores selling BRK products do not have the right to alter, modify or any way change the terms and conditions of this warranty. This warranty does not cover normal wear of parts or damage resulting from any of the following: negligent use or misuse of the product, use on improper voltage or current, use contrary to the operating instructions, disassembly, repair or alteration by anyone other than BRK or an authorized service center. Further, the warranty does not cover Acts of God, such as fire, flood, hurricanes or tornadoes. BRK shall not be liable for any incidental or consequential damages caused by the breach of any express or implied warranty. Except to the extent prohibited by applicable law, any implied warranty of merchantability or fitness for a particular purpose is limited in duration to the duration of the above warranty. Some states, provinces or jurisdictions do not allow the exclusion or limitation of incidental or consequential damages or limitations on how long an implied warranty lasts, so the above limitations or exclusion may not apply to you. This warranty gives you specific legal rights, and you may also have other rights that vary from state to state or province to province.

## How to Obtain Warranty Service

**Service:** If service is required, do not return the product to your retailer. In order to obtain warranty service, contact the Customer Service Team at [onelinksupport@firstalert.com](mailto:onelinksupport@firstalert.com) or **1 (833) ONE-LINK** (1-833-663-5465).

To assist us in serving you, please have the model number and date of purchase available when calling.

**For Warranty Service return to: 1301 Joe Battle, El Paso, TX 79936**

**Disposal:** Waste electrical products should not be disposed of with regular household waste. Please recycle where facilities exist. Check local requirements for disposal of Lithium powered electronic devices. The Alarm should be deactivated before disposal. See page 14, “Permanently Deactivating the Alarm”. You can also return your Alarm to us for disposal. For return address see above. Please include a note confirming the product is being returned for disposal.

Communication distance between alarms may vary from home to home depending on environment, construction materials and size of structure. The quantity of alarm required will depend on these factors. See manual for details.

# Copyright and Technical Specifications

©2018 BRK Brands, Inc. All rights reserved. Distributed by BRK Brands, Inc., Aurora, Illinois 60504. BRK Brands, Inc. is a subsidiary of Newell Brands Inc. (NYSE:NWL). Printed in USA.

Apple HomeKit, Apple iPhone, iPad, iPad Air, and iPod touch are trademarks of Apple Inc., registered in the U.S. and other countries. HomeKit is a trademark of Apple Inc. App Store is a service mark of Apple Inc.

The Bluetooth® word mark and logos are registered trademarks owned by Bluetooth SIG, Inc. and any use of such marks by BRK Brands, Inc., is under license. Other trademarks and trade names are those of their respective owners. Wi-Fi® is a registered trademark of Wi-Fi Alliance.

Controlling this HomeKit-enabled accessory automatically and away from home requires an Apple TV with tvOS 10.0 or later or an iPad with iOS 10.0 or later set up as a home hub.

To control this HomeKit-enabled accessory, iOS 10.0 or later is recommended



**FIRST ALERT**

# Onelink.

©2018 BRK Brands, Inc. All rights reserved. • Distributed by BRK Brands, Inc.  
BRK Brands, Inc. is a subsidiary of Newell Brands Inc. (NYSE:NWL)  
3901 Liberty Street Road, Aurora, IL 60504-8122  
Customer Service Team: 1 (833) ONE-LINK (1-833-663-5465)  
[www.onelinkfirstalert.com](http://www.onelinkfirstalert.com) • 10/18 • Printed in USA • MOB-0541-164658